



kitchen think

Instructions for Installation and Use

Freezer
Model RZA 21

To the Installer

Before installation fill in the product details on the back cover of this book.
The information can be found on the rating plate.

To the User

You must read the instructions prior to installing and using the appliance and
then retain them for future reference.

CONTENTS

Product Safety	3
Installation	3
Electrical Connection	4
Get to Know your Appliance	5
Getting your Appliance ready for use	6
How to use your Freezer	6
Food Storage	7-8
Energy Saving Tips	9
Caring for your Appliance	9
Troubleshooting	10
Door reversal	11
Notes	12
After Sales Service	14
Hotpoint Guarantee	15
Key Contacts	Back Cover

Retention of this Instruction Book

This Instruction Book must be kept handy for reference as it contains important details on the safe and proper use of the appliance.

If you sell or pass the appliance to someone else, or move house and leave it behind, make sure this Book is also provided so the new owner can become familiar with the appliance and safety warnings.

If the Book is lost or damaged a copy may be obtained from:
Merloni Elettrodomestici UK Ltd. Morley Way, Peterborough, PE2 9JB

PRODUCT SAFETY

ATTENTION

Read your manual carefully since it contains instructions which will ensure safe installation, use and maintenance of your appliance. Your Refrigerator is built to International safety standards (EN60) and has been awarded the European approval mark (IMQ) for compliance with UK electrical safety requirements. It also meets the EC standards on the prevention and elimination of radio interference (EC directive 87/308 - 02.06.89).

1. This appliance is designed to be used indoors and under no circumstances should it be installed outside even if protected by a roof. Leaving the appliance exposed to the rain and whether is exceedingly dangerous.
2. The appliance should be used only by adults and exclusively for storing foodstuffs in compliance with the instructions provided in this manual. Under no circumstances should children be allowed to operate, or tamper with, this product.
3. Do not attempt to operate or handle this appliance when barefoot, or with wet hands or feet.
4. It is highly recommended that you do not operate this appliance by connecting it to the power supply with extensions or multiple socket plugs. If the refrigerator has been installed between two cabinets, make sure that the supply chord is not dangerously crimped or trapped beneath a heavy object.
5. Never pull the cable or the appliance to remove the plug from the socket; this is exceedingly dangerous.
6. Do not touch the internal cooling elements, especially if your hands are wet, since you could burn or hurt yourself. Do

not place ice cubes straight from the freezer into your mouth as this may result in burns.

7. Before doing any cleaning, disconnect the appliance from the electricity (by pulling out the plug or turning off the general switch in your home).

8. Before disposing of your old appliance, remember to break or remove the lock as a safety measure to protect children who might lock themselves inside the appliance when playing. In addition, if the appliance is a new one with a lock, keep the key out of the reach of small children.

9. If your appliance is not operating properly, read the chapter entitled, "Trouble Shooting", which might help you resolve the problem, before calling an after-sales service centre. Do not attempt to repair the appliance by tampering with the internal components.

10. If the power supply cord must be replaced, please contact one of our Customer Service Centers. In some cases, the connections are made using special terminals and in others a special tool must be used to access the connections.

11. Do not use electric appliances inside the compartment for food storage, if these are not those recommended by the manufacturer.

12. At the end of the functional life of your appliance – containing cyclopentane gas in the insulation foam and perhaps gas R600a (isobutane) in the refrigeration circuit – the latter should be made safe before being sent to the dump.

For this operation, please contact your dealer or the Local Organisation in charge of waste disposal.

INSTALLATION

To ensure that the appliance operates properly and to reduce energy consumption, it is important that the appliance is installed correctly.

Ventilation

The compressor and condenser generate heat and, therefore, need to be ventilated properly. Rooms with less than perfect ventilation are not very suited for installation of the appliance. Therefore, it should be installed in a room with an opening (window or French window) that provide the appropriate amount of air re-circulation. It is also important that the room not be too humid.

During installation, make sure not to cover or obstruct the grates that allow for proper ventilation of the appliance.

For proper ventilation of the appliance, you must leave:

- a space of at least 10 cm between the top part and any cabinets above it;
- a space of at least 5 cm between the sides of the appliance and any adjacent cabinets/walls.

Away from Heat

Avoid positioning the appliance in a place where it is directly exposed to sunlight or near an oven, cook top or the like.

Level

The appliance must be level. If the floor is not level, the adjustable feet located in front can be used to level the appliance.

Electrical Connection and Earthing

Before proceeding with the electrical connection, make sure that the voltage indicated on the rating plate, located within the freezer, corresponds to the mains voltage in your home and that the socket is fitted with a standard earthing wire in accordance with safety standards for 46/90 systems. If the socket is not fitted with an earthing wire, the manufacturer will not be held liability for any damages and or injuries arising out of the use of the appliance. Do not use multiple sockets or adapters.

Position the appliance in such a way that you can access the socket where it is plugged in.

Insufficient power?

The electrical socket must be able to handle the maximum power load of the appliance, which is indicated on the rating plate located within the freezer.

Before making the electrical connection ...

After the appliance has been delivered, place it in the vertical upright position and wait at least 3 hours before inserting the plug into the socket in order to ensure that it functions properly.

ELECTRICAL CONNECTION

Your appliance is supplied with a 13amp fused plug that can be plugged into a 13amp socket for immediate use. Before using the appliance please read the instructions below.

WARNING:

THIS APPLIANCE MUST BE EARTHED.

Replacing fuse covers:

When replacing a faulty fuse, a 13amp ASTA approved fuse to BS 1362 should always be used and the fuse cover re-fitted.

If the fuse cover is lost, the plug must not be used until a replacement is obtained.

Replacement fuse covers:

If a replacement fuse cover is fitted, it must be of the correct colour as indicated by the coloured marking or the colour that is embossed in words on the base of the plug.

Changing the plug:

Removing the plug

If your appliance has a non-rewireable moulded plug and you should wish to remove it to add a longer cable or to re-route the mains cable through partitions, units etc. please ensure that either:

- The plug is replaced by a fused 13amp re-wireable plug bearing the BSI mark of approval.

or

- The mains cable is wired directly into a 13amp cable outlet, controlled by a switch (in compliance with BS 5733) which is accessible without moving the appliance.

Disposing of the plug

Cut off and dispose of the supplied plug if it does not fit your socket. The cable should be cut as close as possible to the moulded plug.

Remove the fuse.

WARNING:

To avoid a shock hazard do not insert the discarded plug into a socket anywhere else.

Fitting a new plug

IMPORTANT:

WIRES IN THE MAINS LEAD ARE COLOURED IN ACCORDANCE WITH THE FOLLOWING CODE...

Green and Yellow	- Earth
Blue	- Neutral
Brown	- Live

As the colours of the wires in the mains lead may not correspond with the coloured markings identifying the terminals in your plug, proceed as follows:

- Connect Green and Yellow wire to terminal marked 'E' or  or coloured Green and Yellow.
- Connect Brown wire to terminal marked 'L' or coloured red or brown.
- Connect Blue wire to terminal marked 'N' or coloured Black or Blue.

If a 13amp plug (BS 1363) is used it must be fitted with a 13amp fuse. A 15amp plug must be protected by a 15amp fuse, either in the plug or adaptor or at the distribution board.

If you are in any doubt about the electrical supply to your machine, consult a qualified electrician before use.

CE Marking certifies that this appliance conforms to the following EEC directives :
Low Voltage Equipment - 73/23/EEC & 93/68 EEC
Electromagnetic Compatibility 89/336/EEC, 92/31/EEC & 93/68/EEC

GET TO KNOW YOUR APPLIANCE

A Power Supply Indicator Light

The green light will come on and stay on while the appliance is connected to the mains and is operating normally.

B Fast Freeze Indicator Light

This yellow indicator light will come on when the "C" knob is on the **Fast Freeze** setting.

C Temperature Adjustment Knob

This regulates the temperature inside the appliance automatically.
To adjust the temperature control, use a coin to turn the knob.

D Warning Light

When this red warning light comes on for a prolonged period of time, it means that the freezer is not functioning properly and the temperature is rising too much. (Call your Service Centre)

This warning light might come on for a brief period when:

a) the door is left open for an extended period of time (when the freezer is being loaded or unloaded).

b) the "C" knob is turned to the "Fast Freeze" setting.

In these two cases, the fact that the warning light comes on does not indicate that the freezer is malfunctioning or there is a defect.

E Storage Compartments

F Fast freeze Compartment

G Levelling feet

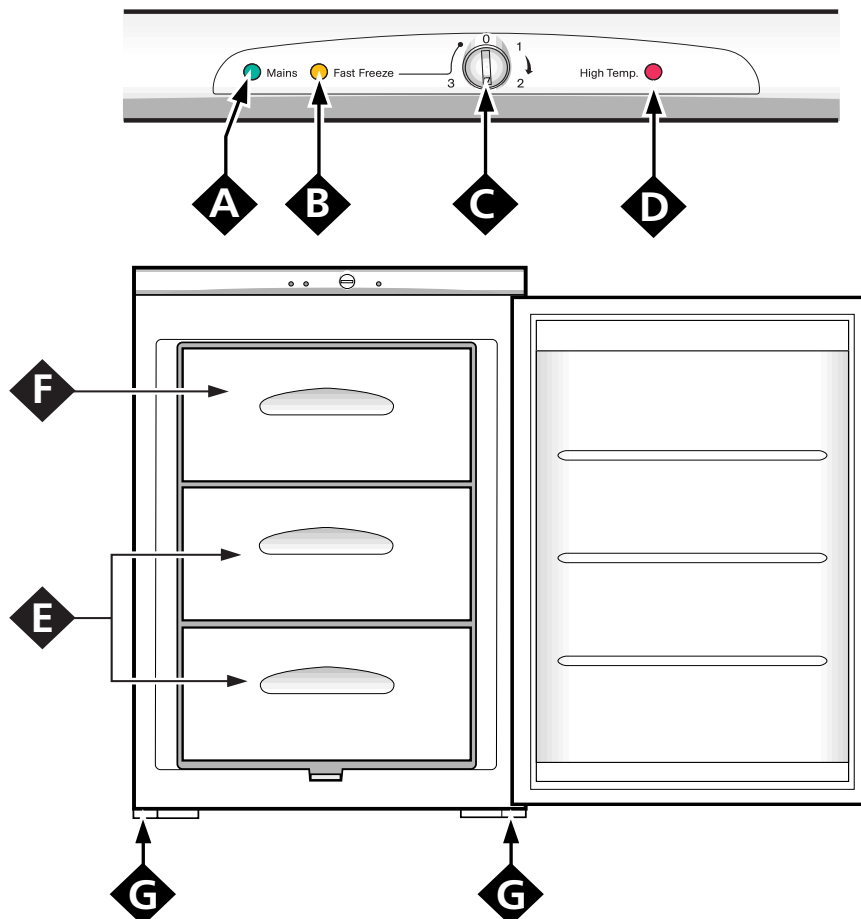

GETTING YOUR APPLIANCE READY FOR USE

NOTICE

After transport stand the appliance upright and wait at least 3 hours before plugging the appliance into the mains to ensure proper performance.

Use average temperature settings to ensure optimum performance and to save energy.

Once the appliance is connected to the mains, the green "A" and the red "D" lights will come on. Turn the "C" knob to the **Fast Freeze** setting (the yellow "B" light will come on). When the red "D" light turns off, turn the "C" knob to one of the normal settings. .

At this point, the freezer is ready for use.

How to use your freezer

Tips on Freezing

- Remember that you should never refreeze products you have allowed to thaw, even if only partially. Once thawed, cook the food, then either eat (within 24 hours) or refreeze it

- Consult a specialized manual when packaging foods for freezing.

- For the best storage and thawing, remember to freeze small portions. This will ensure rapid and uniform freezing. Mark package with a description of the contents and the date it was frozen.

- Freeze only the quantities (in kg) shown on the data plate on the inside of the freezer.

- Turn the "C" knob to the **Fast Freeze** setting (the yellow "B" light will come on).

- Place the fresh food that is being frozen into the top compartments (F), making sure not to place them near food that has already been frozen, but preferably in contact with the cooling surfaces. In fact, proper food storage depends on the speed at which the fresh food is frozen. For this reason, we suggest that the temperature knob be placed on the **Fast Freeze** setting 24 hours before fresh food is placed in the appliance to be frozen. **This operation is necessary for large quantities of food (up to the maximum capacity indicated on the data plate).**

- During the freezing process, avoid opening the door of the freezer.

- Placing substantial amounts of fresh food in the appliance may temporarily raise the temperature within the freezer (the red light will turn on). Since this is a temporary situation, it will not compromise the storage of the food that has already been frozen.

- After 24 hours have passed and the fresh food has been frozen, turn the "C" knob back to one of the normal settings.

Attention: Do not forget to change the temperature setting if you want to avoid **useless wastes of energy.**

- In the case of power failure or breakdown, do not open the freezer door. This will help maintain the temperature inside the freezer, ensuring that foods are conserved for at least 20 hours.

- Do not place full bottles in the freezer because liquids increase in volume when they freeze and this could cause the bottles to burst.

- Fill the ice cube trays three-quarters of the way full.

Storage

Follow the instructions on the packages of frozen foods scrupulously. If none are provided, do not store the food for more than 3 months from the date of purchase.

When purchasing frozen foods, make sure that they have been stored at the proper temperature and that the package is properly sealed. When purchasing frozen foods, it is best to transport them in appropriate containers to keep them cold and then place them in the freezer immediately.

If the package is damp on the outside or is abnormally swollen, it is likely that the package was stored at an inadequate temperature and the food has deteriorated.

FOOD STORAGE

Meat and Fish

Food	Wrapping	Tenderising (days)	Storage (months)	Thawing Time
Beef Roast	Tinfoil	2 / 3	9 / 10	Not required.
Lamb	Tinfoil	1 / 2	6	Not required.
Pork Roast	Tinfoil	1	6	Not required.
Veal Roast	Tinfoil	1	8	Not required.
Veal/Pork Chops	Each piece wrapped in cling wrap and then in tinfoil (4 to 6 slices)		6	Not required.
Veal/Lamb Cutlets	Each piece wrapped in cling wrap and then in tinfoil (4 to 6 slices)		6	Not required.
Minced Meat	In aluminium containers covered with cling wrap.	Freshly minced	2	Slowly in refrigerator.
Heart and Liver	Plastic Baggies		3	Not required.
Sausages	Cling Wrap or Tinfoil		2	As necessary.
Chicken and Turkey	Tinfoil	1 / 3	9	Very slowly in refrigerator.
Duck and Goose	Tinfoil	1 / 4	6	Very slowly in refrigerator.
Pheasant, Partridge and Wild Duck	Tinfoil	1 / 3	9	Very slowly in refrigerator.
Hare and Rabbit	Tinfoil	3 / 4	6	Very slowly in refrigerator.
Venison	Tinfoil or Cling Wrap	5 / 6	9	Very slowly in refrigerator.
Large Fish	Tinfoil or Cling Wrap		4 / 6	Very slowly in refrigerator.
Small Fish	Plastic Baggies		2 / 3	Not required.
Crustaceans	Plastic Baggies		3 / 6	Not required.
Shellfish	Store in salted water in aluminium containers or plastic containers.		3	Very slowly in refrigerator.
Boiled Fish	Tinfoil or Cling Wrap		12	In hot water.
Fried Fish	Plastic Baggies		4 / 6	Directly in pan.

FOOD STORAGE

Fruits and Vegetables

Food	Preparation	Blanching Time	Wrapping	Storage (months)	Thawing Time
Apples and Pears	Peel and cut into slices.	2'	In Containers (cover with syrup)	12	In refrigerator very slowly
Apricots, Peaches, Cherries and Plums	Peel and pit.	1' / 2'	In Containers (cover with syrup)	12	In refrigerator very slowly
Strawberries Blackberries and Raspberries	Rinse and fry.		In Containers (cover with sugar)	10 / 12	In refrigerator very slowly
Cooked Fruit	Cut, cook and strain.		In Containers (add 10% sugar)	12	In refrigerator very slowly
Fruit Juice	Wash, cut and crush.		In Containers (sugar to taste)	10 / 12	In refrigerator very slowly
Cauliflower	Remove leaves, cut head into small pieces and blanch in water and a little lemon juice.	2'	Plastic Baggies	12	Not required.
Cabbage and Brussel Sprouts	Wash and cut into small pieces.	1' / 2'	Plastic Baggies	10 / 12	At room temperature.
Peas	Shell and wash.	2'	Plastic Baggies	12	Not required.
French Beans	Wash and slice if required.	2	Plastic Baggies	10 / 12	Not required.
Carrots, Peppers and Turnips	Peel, wash and slice if necessary.	3' / 4'	Plastic Baggies	12	Not required.
Mushrooms and Asparagus	Wash, peel and cut up.	3' / 4'	Plastic Baggies or Containers	6	At room temperature.
Spinach	Wash and mince.	2'	Plastic Baggies	12	At room temperature.
Vegetable for Soups	Wash and cut up in small pieces.	3'	Plastic Baggies or Containers	6 / 7	Not required.
Various Foods	Preparation	Blanching Time	Wrapping	Storage (months)	Thawing time
Bread			Plastic Baggies	4	At room temperature and in the oven.
Cakes			Plastic Baggies	6	About 10 minutes at room temperature, cook at 100/200°C.
Cream			Plastic Containers	6	At room temperature or in refrigerator.
Butter			In original wrapping or tinfoil	6	In refrigerator.
Boiled Food or Vegetable Soup			Plastic or Glass Containers	3 / 6	At room temperature or in hot water.
Eggs			Freeze without shells in small containers	10	At room temperature or in refrigerator.

ENERGY SAVING TIPS

- Install the Appliance Correctly

This means that the appliance should be installed away from sources of heat or direct sunlight, in a well ventilated room.

- Correct Temperature Settings

Set the freezer temperature knob to one of the medium settings. Very low temperatures will not only consume a great deal of energy, but will neither improve nor lengthen the storage life of the food.

- Shut the Doors

Open your appliance only when strictly necessary - every time you open the door most of the cold air will be lost. In order to restore the correct temperature, the motor will have to run and consume energy.

- Check the Door Seals

Keep the seals clean and pliable so that they fit closely against the door to ensure that no cold air is lost.

- Avoid Frost Buildup

Remember to check the sides of the freezer for frost. When the frost becomes too thick, defrost the freezer immediately (See, "Caring for Your Appliance").

CARING FOR YOUR APPLIANCE

Before doing any cleaning, disconnect the appliance from the electricity (by pulling out the plug or turning off the general switch in your home).

Defrosting

WARNING: do not damage the refrigeration circuit. Do not use mechanical devices or other tools to speed up the defrosting process, unless they have been recommended by the manufacturer.

It is a good idea to remove the frost buildup from the inside of the appliance from time to time.

Make sure not to use pointed metal objects to do so as this could result in piercing the refrigeration circuits, causing irreparable damage to the appliance. Use the plastic scraper provided with the freezer.

To defrost the freezer completely (which should be done once or twice a year), disconnect the appliance from the power supply and leave the door open until all the frost has melted.

The freezer is equipped with a system to drain the water from the defrosting procedure. Simply, place a container in the position indicated in fig. 1.

To speed up defrosting, one or more pots of warm water can be placed inside the appliance.

While defrosting the freezer, it is a good idea to wrap the food taken from the freezer in several layers of paper and place it in a cool place. Since the temperature of the frozen food will inevitably rise, it is best to consume it quickly as its storage life will have been shortened.

Cleaning and Maintenance

The inside of the freezer should be cleaned on a periodic basis after it has been defrosted. Only use a water and bi-carbonate solution to clean the appliance. Do not use abrasive cleaning products, detergents or soap. After the inside has been cleaned, rinse well with clean water and dry carefully.

Once the appliance has been cleaned, turn on the appliance, following the instructions in "Setting Up Your Appliance."

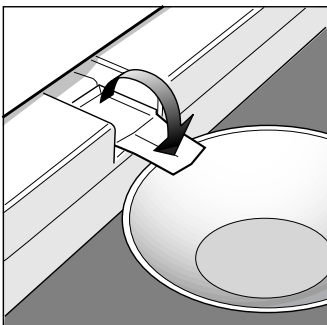

Fig. 1

TROUBLESHOOTING

The Green Light is Off

Have you checked if:

- there is power to the unit?
- the main power switch to the house is on?
- Check the plug is firmly position in the wall socket and the power supply is switched on.
- Check that the thermostat setting is not in the Off position
- Check the power supply with another appliance
- Check the fuse in the plug

The Red Alarm Light is Always On

Have you checked if:

- the door is closed properly and the seal is still OK?
- the door is being opened too often?
- the temperature knob is on the right setting?
- there is too much frost buildup?

The Motor Runs Constantly

Have you checked if:

- the yellow light is on (constant operation setting)?
- the thermostat is on the right setting?

The Appliance Makes Too Much Noise

Have you checked if:

- the freezer is level?
- the appliance has been installed between cabinets that vibrate and make noise?
- it is the noise made by the refrigerant, which occurs even when the compressor is off (this is not a defect).

If after all the checks, the appliance still does not operate or the problem persists, call the nearest Service Centre and inform them of: the type of problem, the abbreviation of the model name (Mod.) and the relative numbers (S/N) written on the rating plate located within the freezer (see examples in the figures below).

Mod. RG 2330		TI	Cod. 93139180000		S/N 704211801	
240 V-	50 Hz	150 W	W	Fuse	A	Max 15
Total	340	75			Freez. Capac	Class
Gross Bruto Brut		Gross Bruto Brut	Net Util Utile	Gross Bruto Brut	Poder de Cong kg/24 h	Clase N Classe
Compr. Syst.	R 134 a	Test P.S-l.	Pressure HIGH-235	LOW 140		
Kompr.	kg 0,090	Made in Italy		13918		



Never call on unauthorized technicians and always refuse spare parts which are not originals.

DOOR REVERSAL

Warning: Before attempting to remove the door, switch off the electrical supply and pull out the mains plug.

It is recommended that you remove any loose items/fittings from inside the appliance and place food into insulated containers whilst carrying out this operation.

You may require assistance to carefully lay the appliance onto its back onto suitable protective materials (i.e. original packaging).

Remove the door

1. Lay down the appliance on its back.
2. Unscrew, remove and retain the bottom hinge pin.
3. Slightly open the door and slide downward, remove and carefully place to one side.
4. Unscrew the hinge pin from the top right hand side and refit the pin into the hole in left hand side.
5. Use a thin blunt instrument to remove the top and bottom hinge bushes and blanking plugs from the door, take care not to mark the door handle.
Reposition the blanking plugs and bushes on the opposite side.

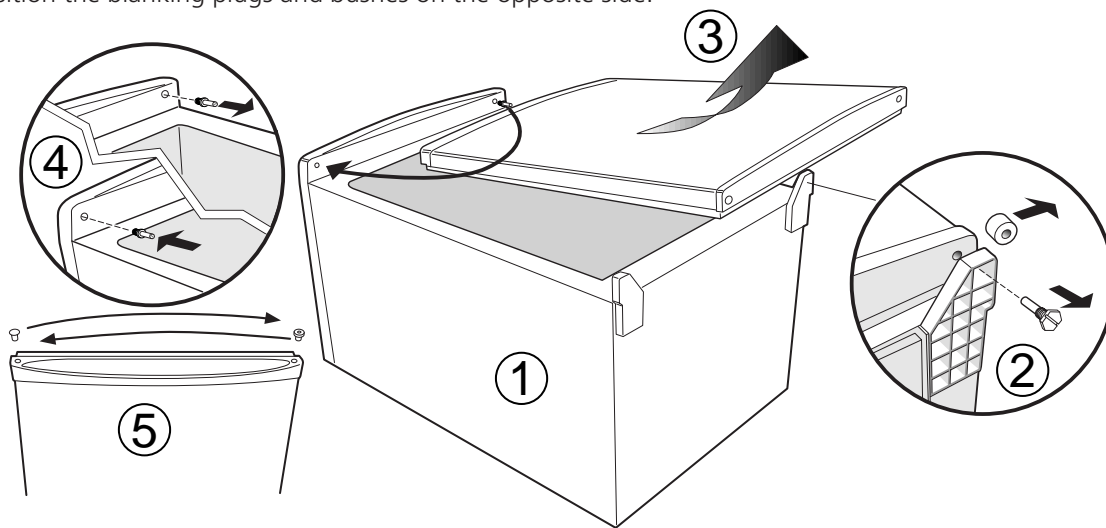

Replacing the door

1. Carefully slide the door upward into the hinge pin.
2. Fit the bottom hinge pin making sure that the door is aligned to the cabinet.
3. Carefully stand the appliance upright in it's required location and make sure it is sitting level on the floor. Open and close the door checking that the gasket makes a good seal without any gaps when the door is closed.

Note: Replace loose items/fittings back into the appliance and leave for at least 15 minutes before switching back on.

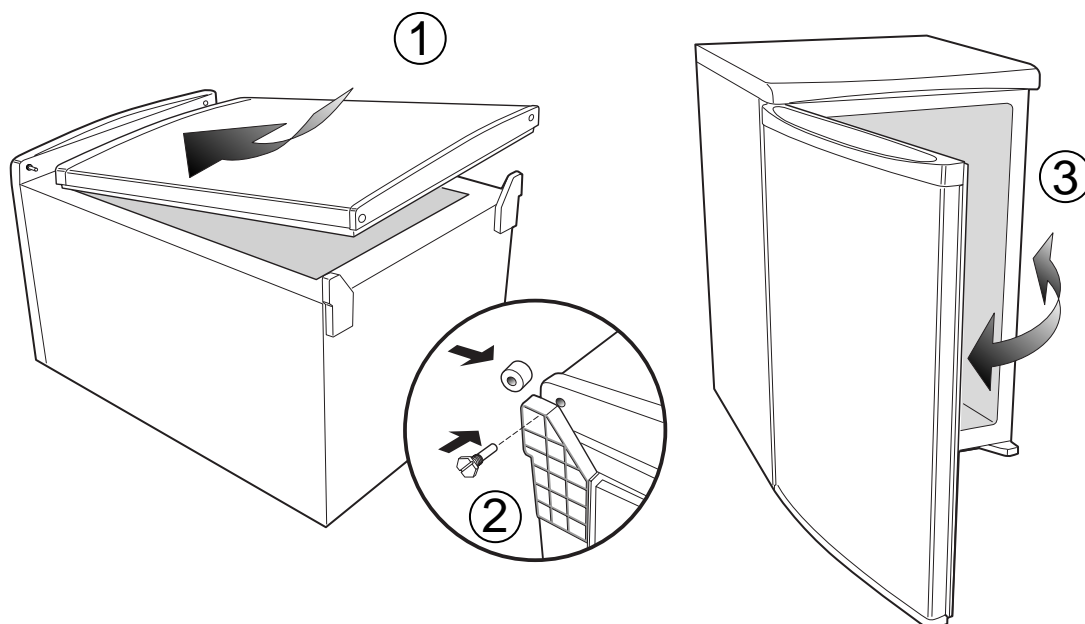

NOTES

NOTES



After Sales Service

"No company is better positioned to offer an after sales service on a Hotpoint appliance than us - the manufacturer"

As part of our commitment to you, all Hotpoint appliances have the added benefit of a fully inclusive parts and labour guarantee for the first 12 months. In addition to this you also have the advantage of **free replacement parts for the first 5 years** when fitted by a Hotpoint engineer. When the 12 months parts and labour guarantee expires we offer the following after sales service options:

Repair Service and Information Help Desk

UK: 08709 066066

www.theservicecentre.co.uk

Republic of Ireland: 1850 302 200

Note: Our operators will require the Model number and the Serial number of your appliance

Available 364 days a year with a fast, effective and value for money service. We have the largest white goods repair service in the UK with over 1200 of our own fully trained engineers. All repairs include a parts and labour guarantee for 12 months from the date of the repair.

If you require any information or have any questions about your appliance, our operators are on hand with help and advice.

All this ensures that you will receive the best available after sales service possible.

Extended Warranties

UK: 08709 088 088

www.theservicecentre.co.uk

Republic of Ireland: 1850 502 200

Whether you have just one or a number of Hotpoint appliances in your kitchen, we offer two service cover plans to give you total peace of mind.

- Repair Protection Plan period
- Kitchen Cover
- FREE service repairs for a single Hotpoint appliance during the of cover.
- FREE service repairs for all your Hotpoint appliances less than 8 years old.

Genuine Parts and Accessories UK: 08709 077 077

www.theservicecentre.co.uk

Republic of Ireland: (01) 842 6836

A wide range of genuine parts and accessories are available from our hotline or through our web site.

Genuine parts and accessories, extended warranties and service repairs are all available on our web-site at:



www.theservicecentre.co.uk



Guarantee

"Satisfaction guaranteed or your money back"

We give you a unique 'satisfaction guaranteed' promise - **valid for 90 days** - after you have purchased your Hotpoint appliance. If there is a technical problem simply call Hotpoint Repair service or visit our web-site at www.theservicecentre.co.uk and where necessary, we will arrange for an engineer to call. If the technical problem is not resolved under this guarantee, **we will replace your machine or, if you prefer, give you your money back.**

All Hotpoint appliances carry a fully inclusive 12 month parts and labour guarantee as well as free replacement parts for the first 5 years (except microwaves, selected integrated appliances and cooker hoods, which have a one year guarantee) provided that they are fitted by a Hotpoint engineer.

Guarantee terms and conditions

Your guarantee is only applicable in the United Kingdom or Republic of Ireland and is subject to the following provisions that your appliance:

- Has been installed and used correctly in accordance with this instruction booklet.
- Has been used solely for domestic purposes and is located on domestic premises (ie. not for commercial or trade use).
- Has been properly connected to a suitable electrical supply voltage as stated on the appliance rating plate.
- Has not been subject to misuse, accident, modified or repaired by anyone other than one of our own service engineers.



For pre purchase information on any other Hotpoint product call: 08701 50 60 70
or visit: www.hotpoint.co.uk



Recycling & Disposal Information

As part of Hotpoint's continued commitment to helping the environment, Hotpoint reserves the right to use quality recycled components to keep down customer costs and minimise material wastage.

Please dispose of packaging and old appliances carefully.

To minimise risk of injury to children, remove the door, plug and cut mains cable off flush with the appliance. Dispose of these parts separately to ensure that the appliance can no longer be plugged into a mains socket, and the door cannot be locked shut.



Key Contacts

After Sales Service

Over 1200 trained specialists, directly employed by us, ensure that you can have complete confidence in both the appliances and services we offer.



Repair Service and Information Desk

UK: 08709 066 066

(Open 8 to 8 Mon - Fri, 8 to 6 Sat, 10 to 4 Sun & Bank Holidays)

www.theservicecentre.co.uk

Republic of Ireland: 1850 302 200

Note: Our operators will require the following information:

Model number:

Serial number:

Extended Warranties

UK: 08709 088 088

(Open 8 to 8 Mon - Sun)

www.theservicecentre.co.uk

Republic of Ireland: 1850 502 200

Genuine Parts and Accessories

UK: 08709 077 077

(Open 8-30 to 5-30 Mon - Fri & 9 to 12 Sat)

www.theservicecentre.co.uk

Republic of Ireland: (01) 842 6836